

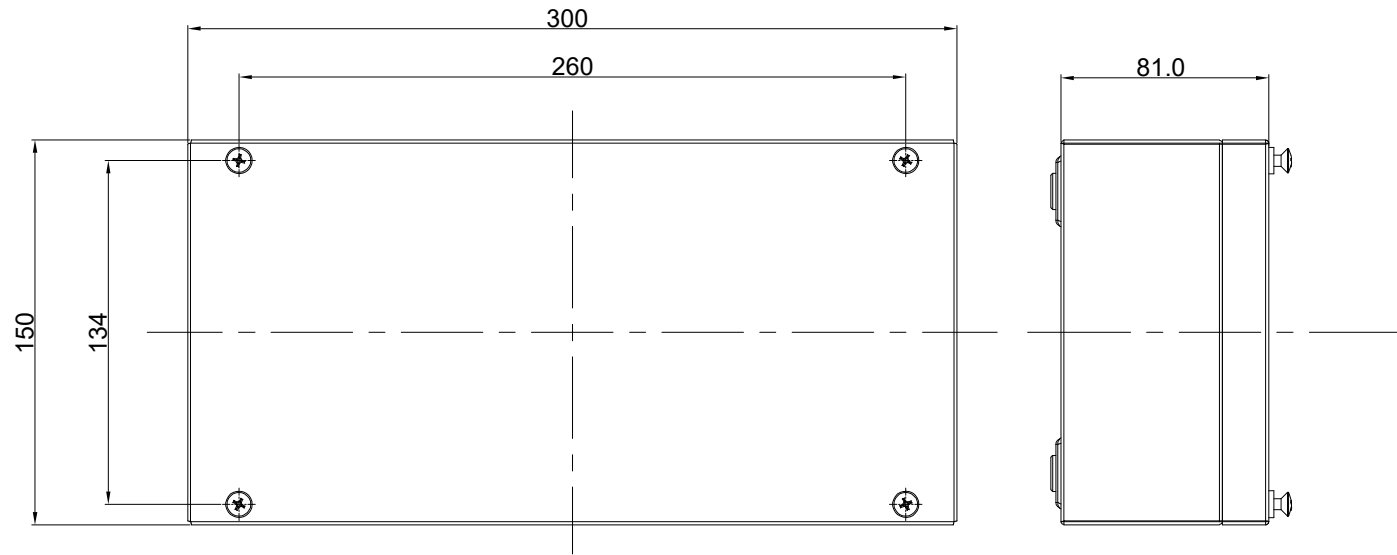

SECTION A-A

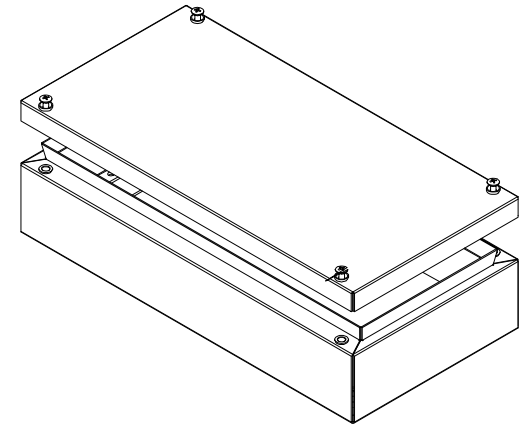
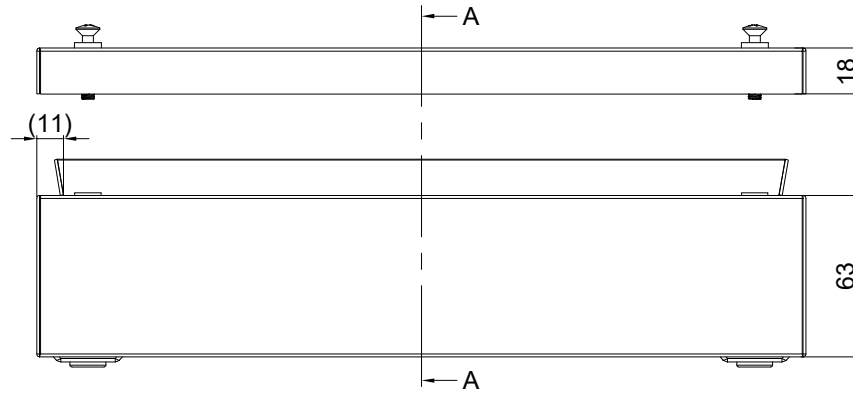
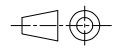

Sr.	Material	Qty.
1	Base (Assembly)	1
1.1	Base	1
1.2	Din Rail Mounting Channel	2
1.3	Blind NutSert M5 - SS A2	4
1.4	Bottom Sealing Cap	4
2	Lid (Assembly)	1
2.1	Lid	1
2.2	Gasket	1
2.3	Plastic captive Screw insert	4
2.4	Stud M6x12 A2	1
2.5	Lid Screw M5 A2 DIN 966	4

Material:- Mild Steel	TITLE :- Steel Junction Box 300 X 150 X 81	This drawing and any information or descriptive material set out on it are the confidential property of Company Name and MUST NOT BE DISCLOSED, COPIED in whole or part or used for any purpose without the written permission of Company Name.
Finish:- Powder coated RAL7001		
General Tolerances DIN ISO 2768c		
All Dimensions: mm		
 FIRST ANGLE PROJECTION DO NOT SCALE	CODE: OGMSJB07	DATE
	 OERIGO GLOBAL PRIVATE LTD	DRG. NO. OG-MSJB-30015081
		CHECKED BY: GA 22/4/22
		REV 00
	SHEET 1 OF 1	

Description	Rev.	Date